

Coolubricator™ & Coolubricator JR™

Operation Manual





unist.com/coolman

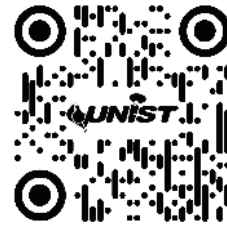

Questions or part orders:

1-800-253-5462 (US & Canada)
1-616-949-0853 (International)

Coolubricator™ & Coolubricator JR™ Operation Manual
Copyright © 2019 Unist, Inc.
02/11/2019 V2.4

Coolubricator™ Quick Start Guide

1. Mount (Pg. 10)

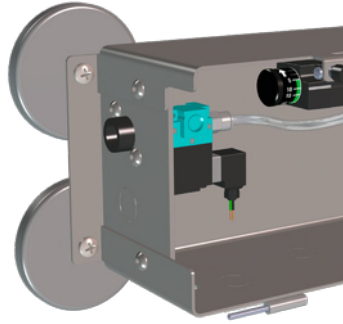

Magnet mount

or

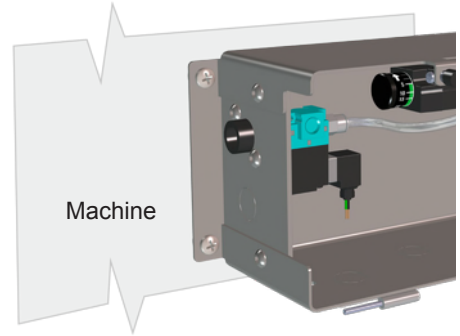

Direct mount

2. Air (Pg. 12)

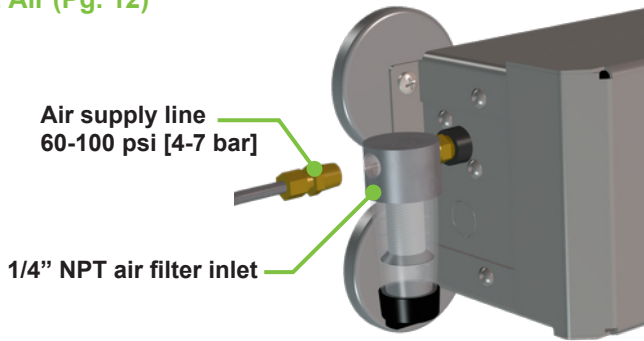

Air supply to filter

or

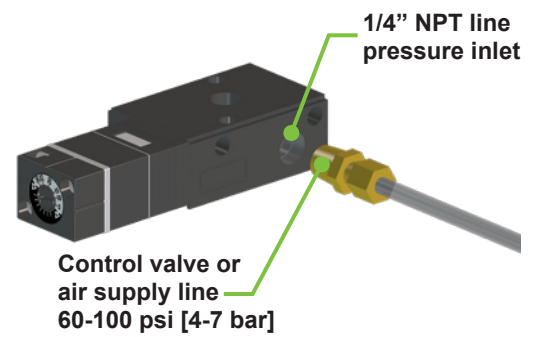

Air supply to manifold

3. Fluid (Pg. 12)



Fill reservoir

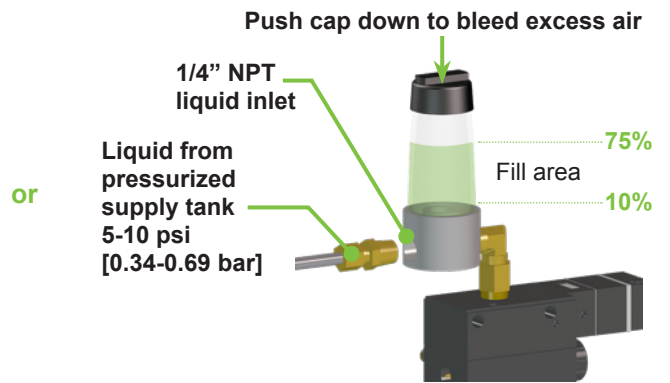

Bleed trapped air

4. Prime (Pg. 15)

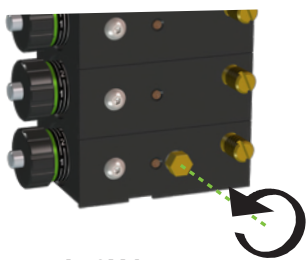

A. 2X Loosen

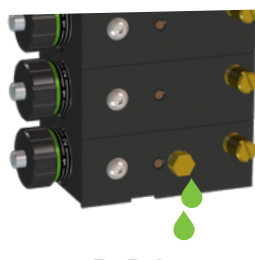

B. Drip

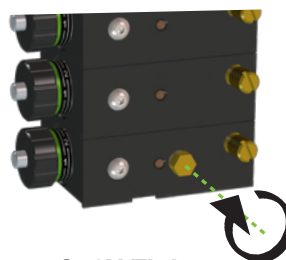

C. 2X Tighten

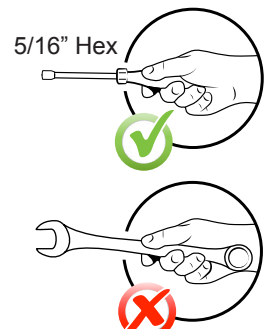

5/16" Hex



Do Not Overtighten

Important Operator Information



Consult this documentation in all cases where this caution symbol appears. This symbol is used to inform you of any potential HAZARD or actions that require your attention.

Use of this equipment in a manner other than that specified by Unist, Incorporated may compromise design integrity and become unsafe.

WARNING: This equipment is not intended for use in explosive environments.

ADVERTENCIA: Este equipo no está diseñado para uso en atmósferas explosivas.

AVVERTIMENTO: Questa apparecchiatura non è inteso per l'uso in ambienti esplosivi.

WARNUNG: Das Ausrüstung darf in einer explosiven Umgebung NICHT verwendet werden.

AVERTISSEMENT: Cet équipement n'est pas prévu pour une utilisation dans des environnements explosifs.



WARNING: This product can expose you to chemicals, including lead, which is known to the State of California to cause cancer, birth defects, or other reproductive harm. For more information go to www.p65warnings.ca.gov.

ADVERTENCIA: Este producto puede exponerlo a productos químicos, incluido el plomo, que el estado de California sabe que causan cáncer, defectos de nacimiento u otros daños reproductivos. Para obtener más información, vaya a www.p65warnings.ca.gov.

AVVERTIMENTO: Questo prodotto può esporre a sostanze chimiche, incluso il piombo, che è noto allo Stato della California come causa di cancro, difetti alla nascita o altri danni riproduttivi. Per ulteriori informazioni, visitare www.p65warnings.ca.gov.

WARNUNG: Dieses Produkt kann Sie Chemikalien, einschließlich Blei, aussetzen, von denen der Staat Kalifornien weiß, dass sie Krebs, Geburtsfehler oder andere Fortpflanzungsschäden verursachen. Weitere Informationen finden Sie unter www.p65warnings.ca.gov.

AVERTISSEMENT: Ce produit peut vous exposer à des produits chimiques, y compris le plomb, qui est connu par l'État de Californie pour causer le cancer, des malformations congénitales ou d'autres problèmes de reproduction. Pour plus d'informations, visitez www.p65warnings.ca.gov.

Identifying Symbols



Caution - ISO 7000-0434B

Table Of Contents

Introduction.....	1-3
Thank You.....	1
System Introduction.....	1
Common Configurations.....	2
Key Components.....	3
The Pump.....	3
The Pulse Generator.....	3
Output.....	3
Standard Pump Identification Charts.....	4
MV Pump Identification Charts.....	5
System Layout.....	6
System Specifications.....	7
System Installation.....	8-13
Mounting Dimensions.....	8-9
Systems With Enclosures.....	8
Systems Without Enclosures.....	9
Reservoirs.....	9
Installation.....	10-13
Position & Mount System.....	10
Connect Control Valve.....	10
Connect Low Level Switch (If Applicable).....	11
Attach Air Supply.....	12
Fill Reservoir Or Air Trap.....	12
Position & Install Nozzles.....	13
System Startup.....	14-18
Turning The System On & Off.....	14
Prime The Pumps.....	15
Setting Pump Stroke.....	15
Approximate Standard Pump Output Per Stroke.....	16
Approximate MV Pump Output Per Stroke.....	16
Adjust Pulse Generator.....	17
System With Knob.....	17
System Without Knob.....	17
Adjust Airflow.....	17
Approximate Air Metering Screw Air Flow Rate.....	18

Table Of Contents

Nozzles	19-20
Nozzle Styles.....	19
Connecting & Disconnecting Tubing & Nozzles	20
Troubleshooting	21-22
Appendix A: System Spare Parts.....	23
Appendix B: Nozzle Spare Parts.....	24
Appendix C: Standard Pump Components.....	25
Appendix D: MV Pump Components	26
Appendix E: System Part Numbering Scheme	27
Appendix F: Nozzle Part Numbering Scheme.....	28
Notes.....	29-31

Introduction

Thank You

Thank you for your purchase of the Unist Coolubricator™. Please take the time to read this operation manual to take full advantage of your new Coolubricator™.

The Unist Coolubricator™ uses a positive-displacement pump to give a continuous spray of fluid at a precise rate. The system offers flexibility while maintaining simplicity and can be operated using only compressed air.



Figure 1: Coolubricator™ system



Figure 2: Coolubricator JR™ system

System Introduction

The Coolubricator™ gives simple, precise lubrication. Two types of pumps are available: atomizing pumps that provide an air and oil mix, and oil-only pumps. These adjustable positive-displacement pumps are proven with a track record of consistency and reliability. Their modular design allows multiple pumps to be stacked together when more than one output is required, so each system can be tailored specifically for the application. Each pump stack includes a stroke adjustment for the pump output and a pulse generator to control the cycle rate of the pump.

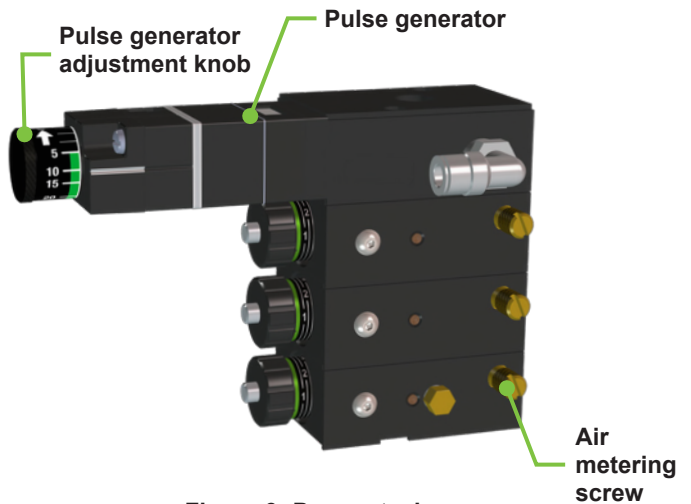

Figure 3: Pump stack

Atomizing pumps also have an air metering screw to regulate the output air flow. The combination of these adjustments gives complete control of the spray output.

It is not only the adjustability and precision of the Unist Coolubricator™ that keeps our customers satisfied, but also our unrivaled quality. Unist products are built to provide years of service in tough, industrial environments. We take pride in the quality of our equipment and each Unist system is thoroughly tested in our shop before making its way to yours.

Introduction

Common Configurations

The Coolubricator's™ modularity gives each customer the flexibility to configure a unit exactly as needed. Because of this, there are thousands of Coolubricator™ configurations. They may look different because of the presence or absence of an enclosure or the size of the reservoir, but regardless of the look, all Coolubricators™ have the same key components which use the same simple adjustments. The examples provided below illustrate some of these different looks.



Figure 4: Single pump output system with an enclosure

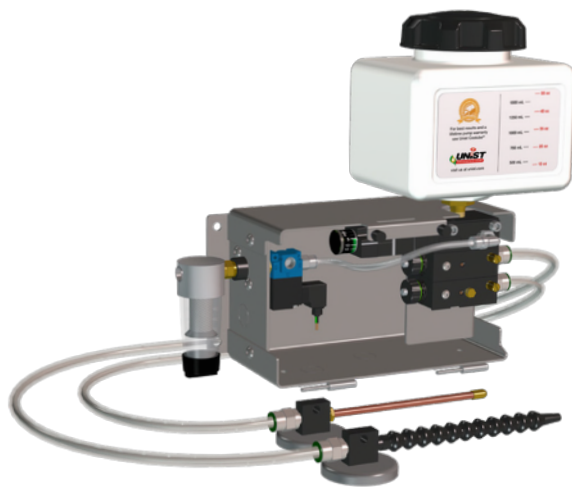

Figure 5: Multiple pump output system with an enclosure



Figure 6: Single pump output system without an enclosure

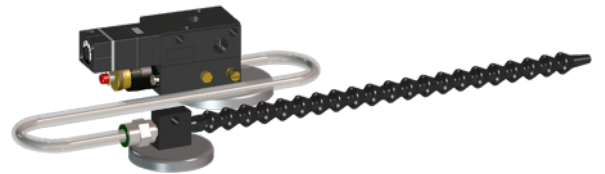

Figure 7: Single pump output system without an enclosure & reservoir

Unist systems perform best with our Coolube® line of lubricants. Coolube's® 100% natural, non-toxic, renewable plant oil-based composition makes it an ideal choice for manufacturers who care about their environmental impact. Coolube® contains no petroleum products, is 100% chlorine and silicone free, and produces no harmful VOC's. Coolube® is completely biodegradable, yet still has a long shelf life. An added benefit is your system's pump is guaranteed for life when used exclusively with Unist Coolube® lubricant.



Figure 8: Coolube® lubricant

Introduction

Key Components

The Pump

In most cases, the Coolubricator™ provides an atomized oil and air mixture that is delivered to the work interface. For some applications, it can be configured with an oil-only pump, so only fluid is delivered. The oil is metered using a pneumatically actuated positive-displacement pump and the output per stroke is adjusted with the pump stroke adjustment knob.

There are many variations of pumps used in the Coolubricator™ system based on the viscosity of the fluid being used, the output rate required, if it is an air atomizing or an oil-only pump, and where the pump is located in the pump stack. The charts on pages 4 and 5 will help identify which style of pumps is/are in your system.

On an atomizing pump, the air flow is controlled with an air-metering screw. The volume of oil supplied with each pump stroke is controlled by the pump stroke adjustment knob. The density and distance of the spray is determined by these two adjustments.

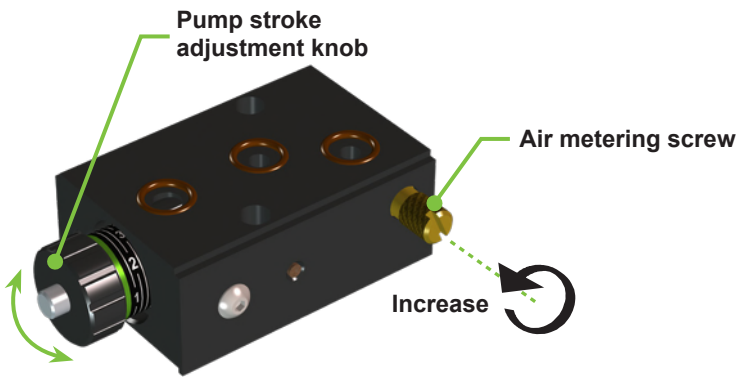

Figure 9: Air metering screw & pump stroke adjustment

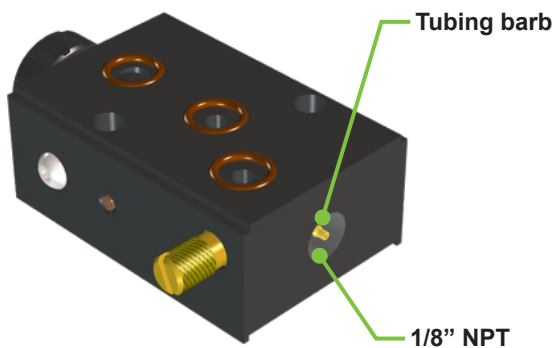

Figure 10: Outlet port

The Pulse Generator

The pulse generator is a variable pneumatic timer specially designed and manufactured by Unist to give consistent control of the pump cycle rate. Because this is a pneumatic and not an electronic circuit, the exact rate of the pulses are subject to changes in air pressure and other mechanical variations. The numbers on the dial should be used as rough approximations of the pulses per minute at 80 psi [5.52 bar]. If an exact value is needed, regulated air is recommended and the frequency should be set by adjusting the knob so that the pump strokes at the desired rate as measured with a timer.

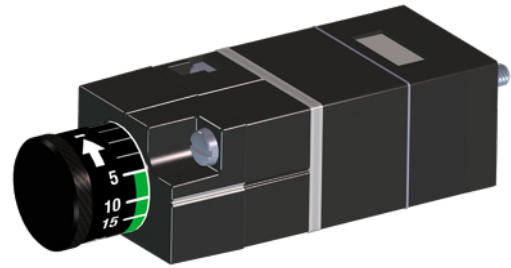

Figure 11: Pulse generator

Output

If the Coolubricator™ is designed to deliver an air and oil spray, keeping the fluid and air separate until the point of application is the key to delivering consistent spray output. Unist's coaxial outputs excel at this by combining the fluid and air directly at the nozzle tip. The "jacket of air" surrounding the fluid outlet evenly atomizes the fluid and delivers it to the target in a balanced spray pattern. In the oil-only case, the output from the Coolubricator™ can be connected directly to the point(s) of application.

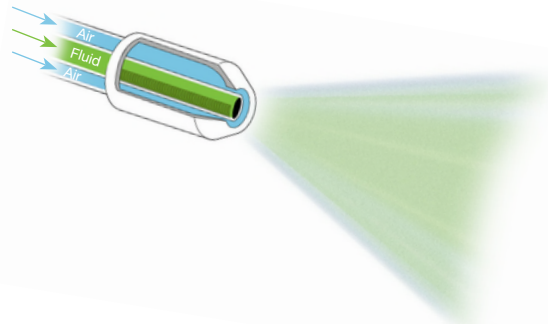
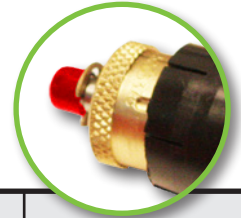





Figure 12: Air & oil spray

Standard Pump Identification Charts

1-Drop Standard Pump (Red Cap) (Knurled brass adjustment knob with black body)



Features	Air metering screw	Air metering screw & drain plug	None	Drain plug
Pump				
Part #	94-6811	94-6821	94-6811-1	94-6821-1
Location	intermediate	bottom	intermediate oil-only	bottom oil-only

3-Drop Standard Pump (Black Cap) (Knurled brass adjustment knob with black body)

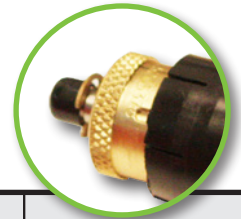





Features	Air metering screw	Air metering screw & drain plug	None	Drain plug
Pump				
Part #	94-6813	94-6823	94-6813-1	94-6823-1
Location	intermediate	bottom	intermediate oil-only	bottom oil-only





Figure 13: Standard pump identification charts

MV Pump Identification Charts

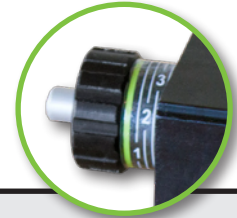
1-Drop MV Pump (Green Band)

(Anodized aluminum adjustment knob with black body)



Features	Air metering screw	Air metering screw & drain plug	None	Drain plug
Pump				
Part #	302098	302099	302416	302417
Location	intermediate	bottom	intermediate oil-only	bottom oil-only

2-Drop MV Pump (Red Band)

(Anodized aluminum adjustment knob with black body)

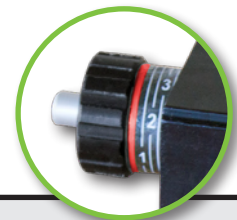





Features	Air metering screw	Air metering screw & drain plug	None	Drain plug
Pump				
Part #	302100	302101	302418	302419
Location	intermediate	bottom	intermediate oil-only	bottom oil-only

Figure 14: MV pump identification charts

System Layout

A. Air filter

Standard on every system with enclosure

B. Control valve

Options include solenoid valve (shown), air pilot valve, manual valve, or foot valve

C. Positive-displacement metering pump

Precise and reliable with full stroke outputs of 0.033 mL, 0.100 mL, or 0.045 mL

D. Pneumatic pulse generator

Controls pump cycle rate

E. Air metering screw

Controls nozzle air flow (not present on oil-only pumps)

F. Pump stroke adjustment knob

Controls volume of fluid delivered per stroke

G. 16 oz [473 mL] fluid reservoir

Additional sizes and styles available

H. Rugged steel enclosure

Removable cover for easy adjustment or maintenance (optional keyed lock)

I. Drain plug

Use to empty fluid from pump stack, reservoir, and to bleed trapped air

J. Outlet port

Connection port for coaxial or oil-only outputs

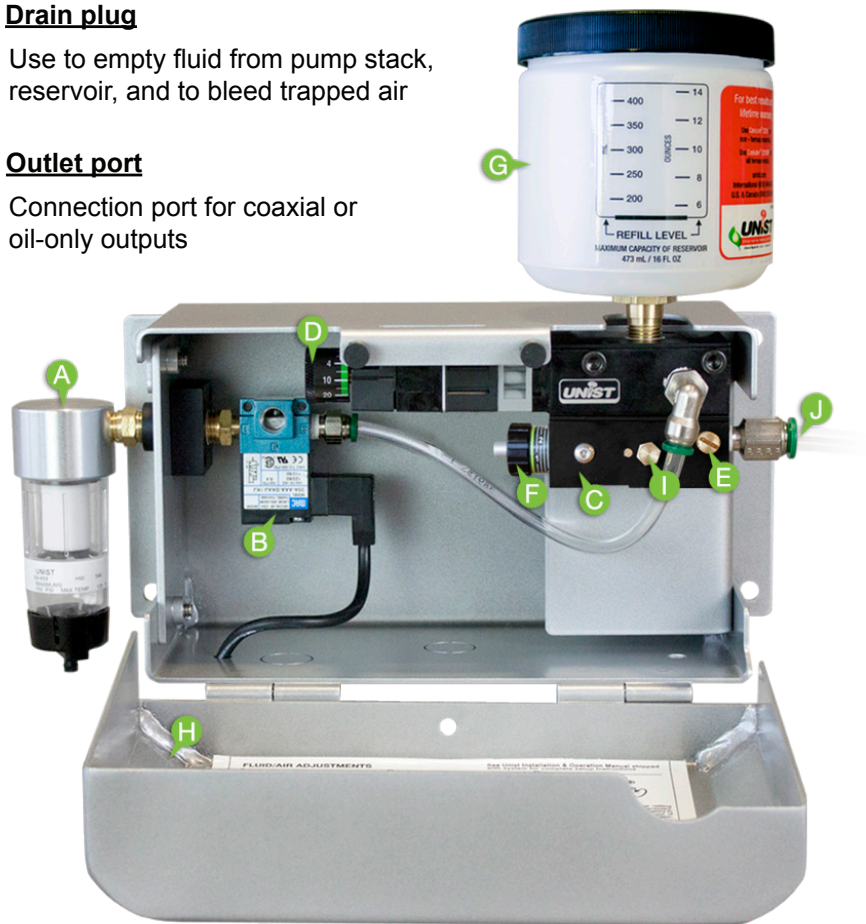

Figure 15: Typical system layout

System Specifications

Supply air pressure	clean, dry compressed air, 60-100 psi [4-7 bar], 25 SCFM [708 LPM] minimum				
Pumps		1-drop standard	3-drop standard	1-drop MV	2-drop MV
	Viscosity	50-1000 SUS	50-1000 SUS	30-1300 SUS	30-500 SUS
	Output at full stroke	0.033 mL	0.100 mL	0.045 mL	0.100 mL
	Output rate	0-396 mL/hr	0-1200 mL/hr	0-540 mL/hr	0-1200 mL/hr
Air flow rate	0-4 SCFM [0-113 LPM] for each air and oil output. 1-2 SCFM [28-56 LPM] typical				
Pulse generator frequency	recommended: 5-50 pulses/minute maximum: 200 pulses/minute (not recommended for continuous operation)				
Operating temperature range	32° -122°F [0°-50°C]				
Storage temperature range	4° -158°F [-16°-70°C]				
Fluid reservoir capacity	reservoir dependent, 16-64 oz [473-1893 mL] fluid supplied through air trap: clean, filtered fluid, 10 psi [0.69 bar] max				

Figure 16: System specifications

System Installation

Mounting Dimensions

Systems With Enclosures

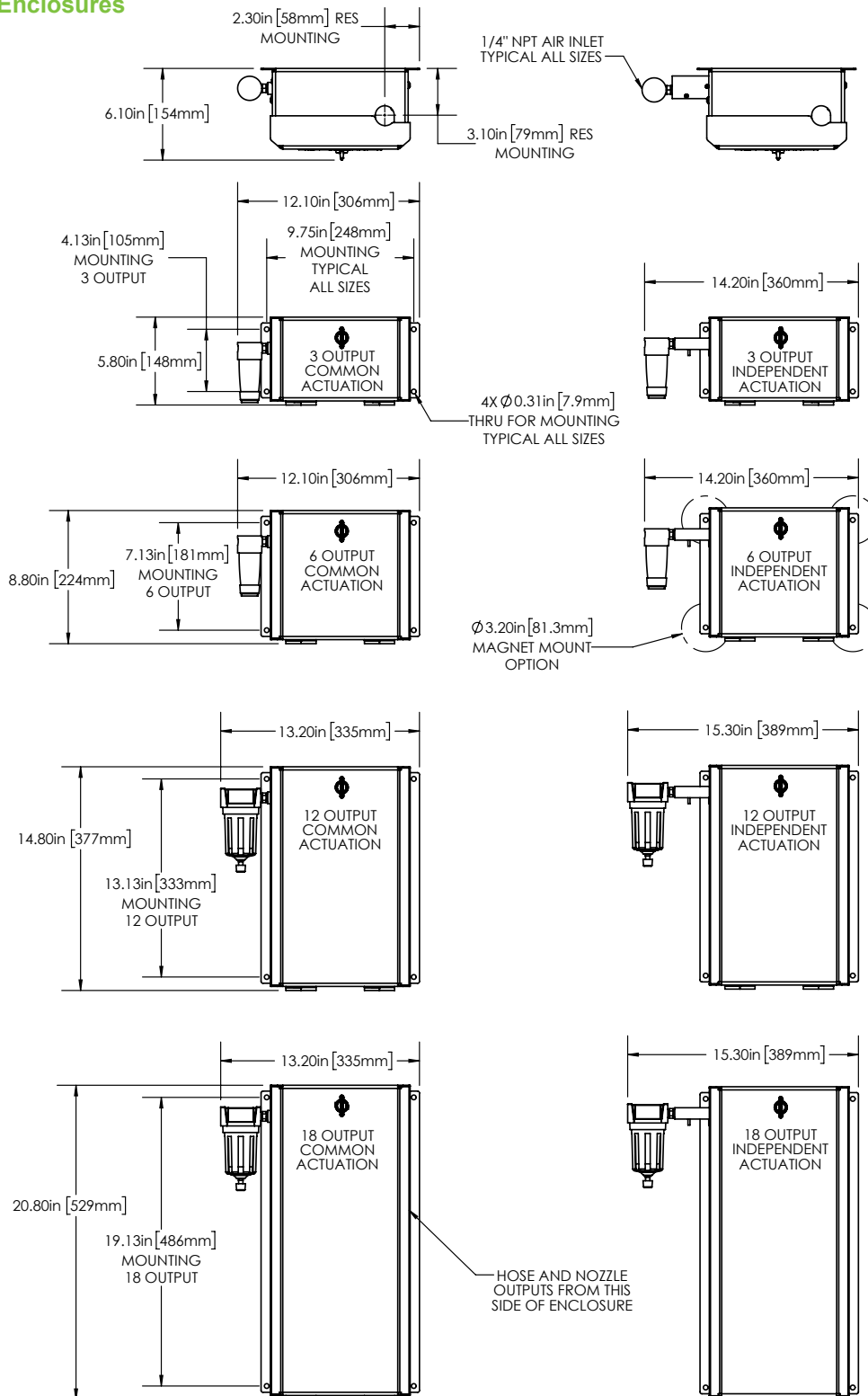

Figure 17: Systems with enclosures

System Installation

Systems Without Enclosures

Each pump is 1" [25.4 mm] tall, so you can determine the height of a system's pump stack (in inches) using this formula:

$$\text{Height} = (\text{number of pumps}) + 1.05$$

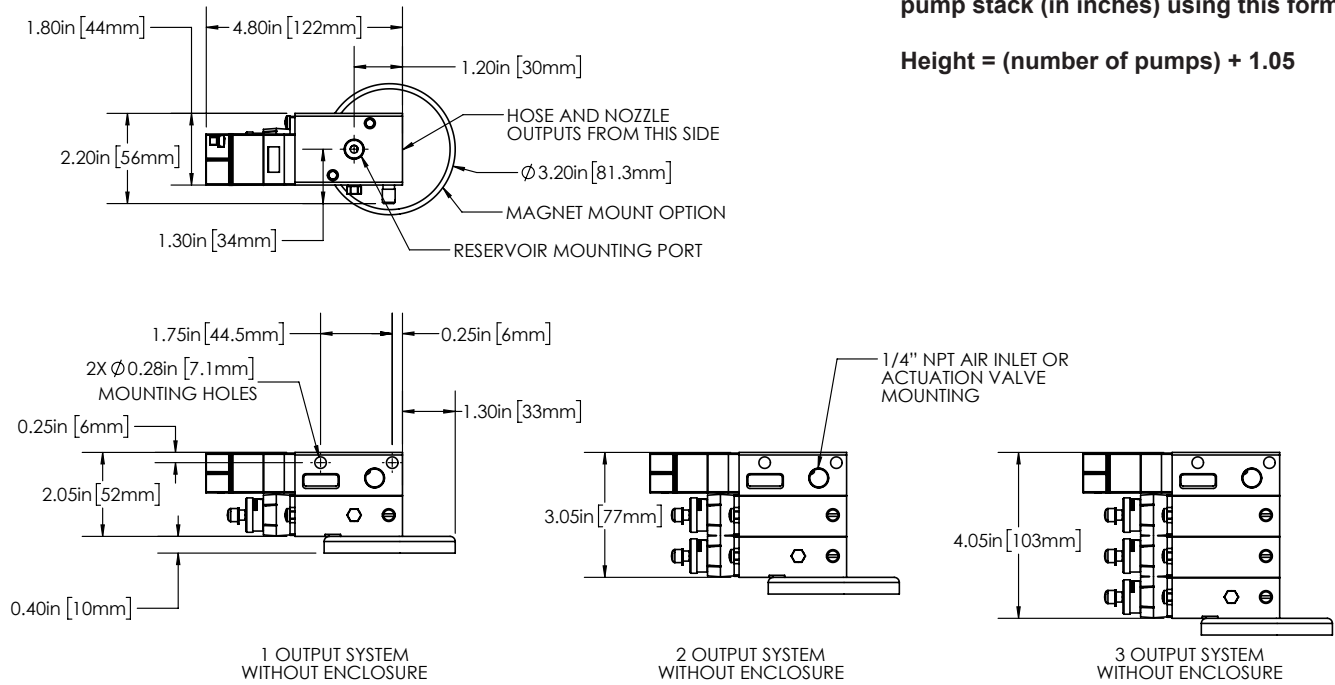

Figure 18: Systems without enclosures

Reservoirs

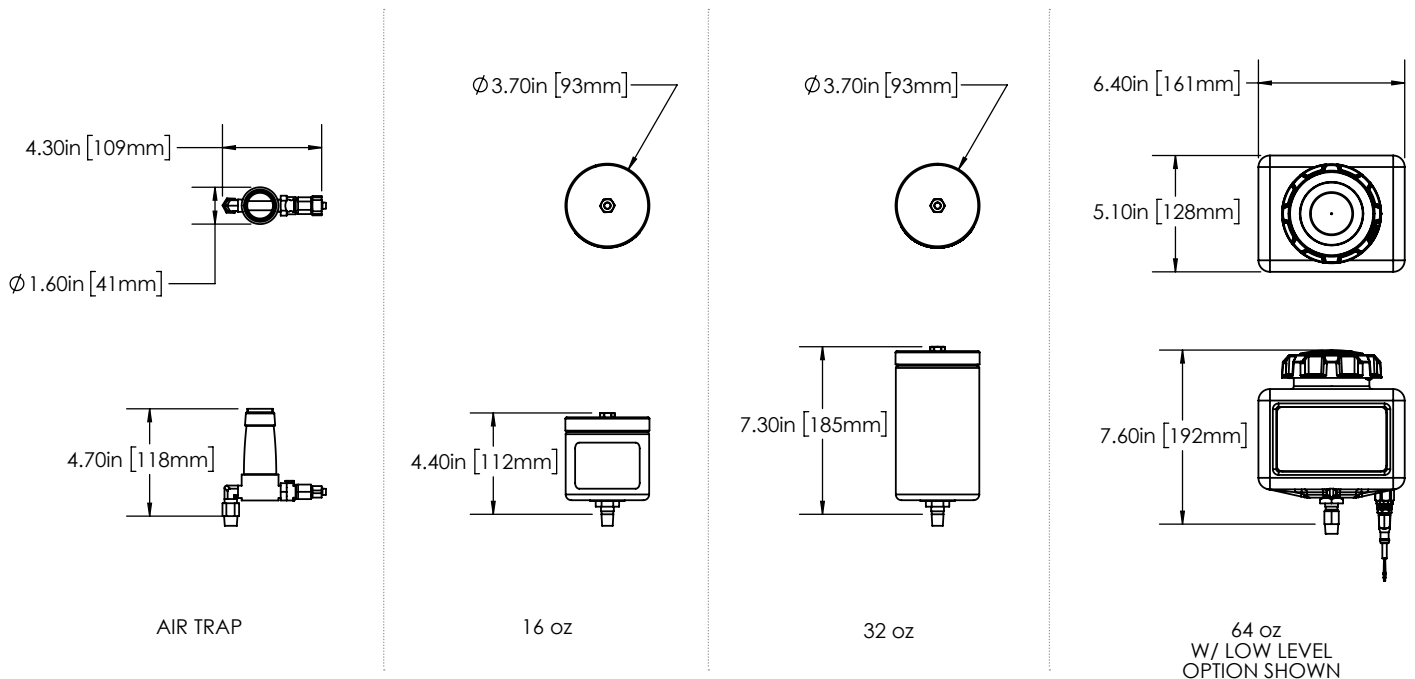

Figure 19: Reservoirs

System Installation

Installation

Position & Mount System

Mount the system in close proximity to the machine, where it is convenient to access and where there are no obstructions that may pinch or kink output or air feed lines. The unit may be mounted directly to the machine, or with optional magnets, and must be mounted so the reservoir is up and the unit is level.

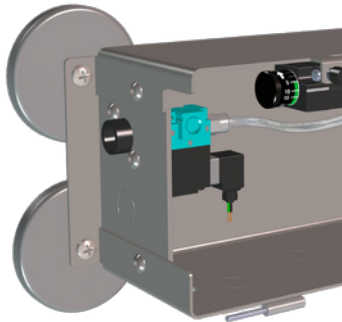

Figure 20: Magnet mount



Attention: The Coolubricator™ must be securely mounted to a suitable mounting surface for safe operation. Use appropriate fasteners in all four mounting positions. Failure to do so could lead to unsafe operation and personal injury.

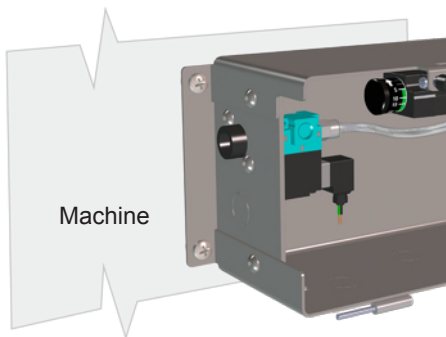

Figure 21: Direct mount



Attention: Always use two people while securing the Coolubricator™ to its mounting surface. Failure to do so could cause personal injury.

Connect Control Valve

The pneumatic circuit on the Coolubricator™ can be controlled with a solenoid valve, a manual slide valve, or an air pilot valve. If the Coolubricator™ is to be turned on whenever the machine is operated, the solenoid valve is wired to the operation circuit on the machine. If independent operation is needed, the solenoid is wired to a separate switch. The voltage, current, and wiring diagrams for the Unist supplied solenoid valves are shown below.

Coolubricator™ Control Valves					
Unist part #	Pipe size	Voltage	Power	Figure	DIN connector size
68-1040-18-12VD	1/8" NPT	12VDC	1.8 W	B	9.4 mm
68-1040-18-24VD	1/8" NPT	24VDC	5.4 W	B	9.4 mm
68-1040-18-24	1/8" NPT	24V 60/50Hz	5.7/7.4 W	A	9.4 mm
68-1040-18-110	1/8" NPT	110V/50Hz 120V/60Hz	5.4 W	A	9.4 mm
68-1040-18-220	1/8" NPT	220V/50Hz 240V/60Hz	5.9 W	A	9.4 mm
68-1040-110	1/4" NPT	110V/50Hz	15 W	A	18 mm
		120V/60Hz	14 W	A	
		24VDC	6 W	B	
68-1040-24VAC	1/4" NPT	24V/60Hz	14 W	B	18 mm
68-1041-18-110	1/8" NPT	110V/50Hz 120V/60Hz	5.4 W	A	9.4 mm
68-1041-1824VAC	1/8" NPT	24V 60/50Hz	5.7/7.4 W	A	9.4 mm
68-1041-1824VDC	1/8" NPT	24VDC	5.4 W	B	9.4 mm

Note: Systems come supplied with 2 meter long DIN connector

CUSTOMER SUPPLIED CONTACT

FIGURE A

CUSTOMER SUPPLIED CONTACT

FIGURE B

Figure 22: Coolubricator™ control valves

System Installation



Attention: Use caution when making electrical connections. Only qualified individuals should attempt to connect input power and control signals to the Coolubricator™. Failure to do so safely could cause damage to property and personal injury.



Attention: Ensure that power is not applied to the Coolubricator™ while connecting solenoid inputs as this could cause personal injury or property damage.

If the system is controlled with a pneumatic air pilot valve, the air pilot signal is connected as shown below.

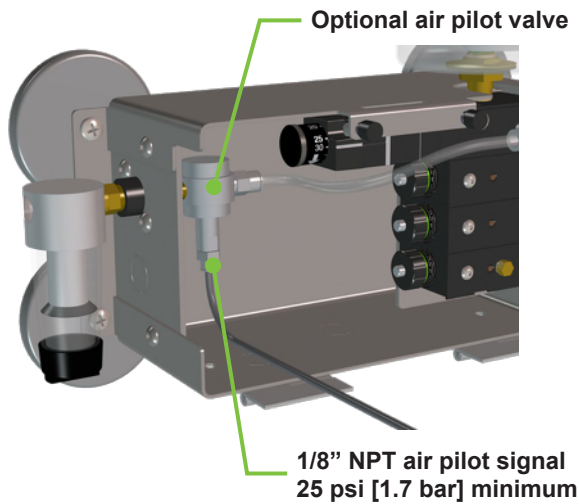

Figure 23: Pneumatic air pilot valve



Attention: Ensure air pressure is not present when connecting the air pilot signal to the Coolubricator™ air pilot valve as this could cause personal injury or property damage.

Connect Low Level Switch (If Applicable)

A low level switch indicates that fluid needs to be added to the system. There are two different styles of switches. One is used in a reservoir and the other in a remote tank. The low level switch can be connected to an input on the machine, an external annunciator, or other device that indicates the fluid level is low. The wiring for each type of switch is shown in Figure 24.

FOR RESERVOIRS



200000 Level Switch

- Minimum media specific gravity: 0.55
- Temperature range: -40–230°F [-40–110°C] oil, 180°F [82°C] max water
- SPST switch, normally closed (NC) contact standard (closed when low). Contact can be changed to normally open (open when low) by inverting float on stem
- Max pressure: 150 psi [10 bar]
- Contact rating: 10 watts, 200 VDC max
- Switching current: 0.5 A

Maximum Resistive Load	
Voltage	Current
0-50VDC	0.2 A
120VAC	0.8 A
240VAC	0.04 A

Caution: Do not directly connect switch to inductive or other high current devices

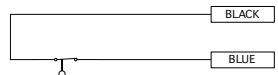

STANDARD NORMALLY CLOSED CONTACT (CLOSED WHEN LOW)



ALTERNATE NORMALLY OPEN CONTACT (OPEN WHEN LOW)

FOR REMOTE TANKS

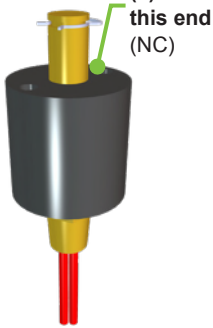

69-5521 Level Switch

- Minimum media specific gravity: 0.55
- Temperature range: -40–230°F [-40–110°C] oil, 180°F [82°C] max water
- SPST switch, normally closed (NC) contact standard (closed when low). Contact can be changed to normally open (open when low) by inverting float on stem
- Max pressure: 150 psi [10 bar]
- Contact rating: 20 watts

Maximum Resistive Load	
Voltage	Current
0-50VDC	0.4 A
120VAC	0.16 A
240VAC	0.08 A

Caution: Do not directly connect switch to inductive or other high current devices

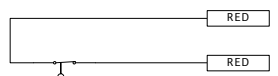

STANDARD NORMALLY CLOSED CONTACT (CLOSED WHEN LOW)



ALTERNATE NORMALLY OPEN CONTACT (OPEN WHEN LOW)

Figure 24: Low level switch

The float is installed at the factory so that the switch is open when the reservoir is full, and closes when the fluid level is low. This works well for turning on alarms and lights. However, if broken wire detection is desired in the circuit logic, this can be changed by inverting the float on the stem so the switch is closed when the reservoir is full and open when it is low.

11

System Installation

Attach Air Supply

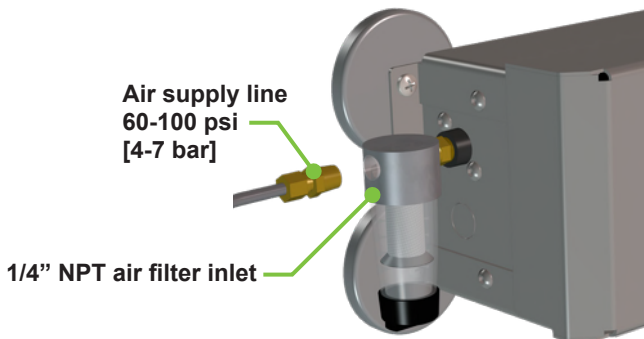

Figure 25: Air supply to filter

Attach air supply line to 1/4" NPT inlet. On units with a steel enclosure the inlet is located on the supplied air filter.

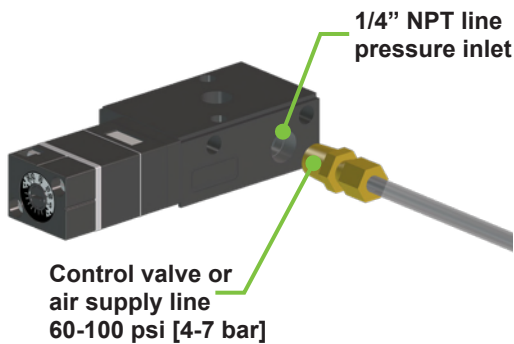

Figure 26: Air supply to manifold

For units without an enclosure, the air supply attaches directly to the control valve, or the top manifold block if no control valve is present. Filtered air should be used for the air supply.



Attention: Use caution when connecting the Coolubricator™ to a compressed air source. Only qualified individuals should make this connection. Failure to do so safely could cause damage to property and personal injury.

Fill Reservoir Or Air Trap

For a system with a gravity feed reservoir, remove the cap, fill the system with the fluid, and replace the cap.



Figure 27: Filling reservoir

If the system is fed pressurized fluid from an external source and is equipped with an air trap, attach the fluid source, set the supply pressure to 5-10 psi [0.34-0.69 bar], and depress the air vent cap until the trap is 75% full. Do this periodically so the air trap does not fill with air.

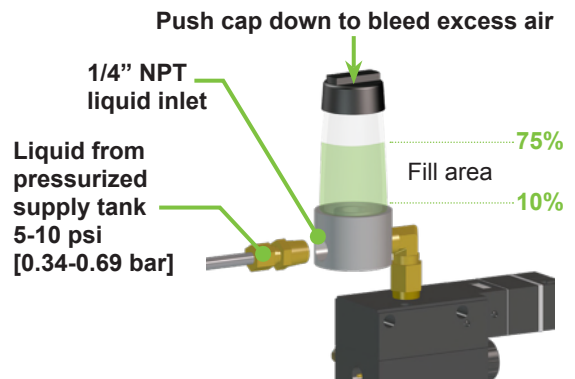

Figure 28: Bleeding air trap



Attention: Use caution while connecting to a pressurized fluid source. Fluid leaks could cause hazardous slippery conditions. Only qualified individuals should attempt to make this connection.

System Installation

Position & Install Nozzles

Keep the nozzle as close as possible to the cutting edge, ideally within 2" [50.8 mm]. The longer the distance that the nozzle needs to spray, the more airflow is needed to carry aerosol and the higher the likelihood of an unwanted mist being generated.

There is a dead zone in fluid coverage when a tool that is perpendicular to the cut. This is because the tool itself blocks the fluid and is generally 180 degrees from the nozzle. Cutting should not be done in this dead zone. If working with a machine that has a fixed position nozzle and may cut in multiple directions, such as a mill, more than one nozzle is recommended to eliminate the dead zone.

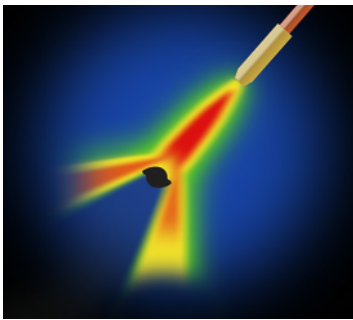

Figure 29: Dead zone with single nozzle output

When face or end milling, the best nozzle location is 135 degrees from the cut in the direction of rotation. 45 degrees does not work as well because chips and turbulence block the fluid from getting to the tool. 135 degrees lubricates the tool before use and minimizes both tool wear and oil use.

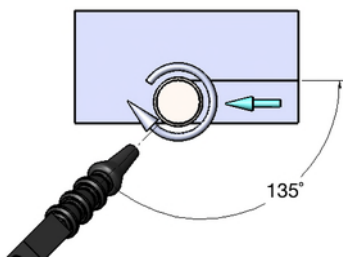

Figure 30: Optimum position of external nozzle for end milling

On the vertical plane, the nozzle should be placed so all the tools to be used are adequately covered by the output spray. For longer tools this means the angle from the vertical is less than the 60-70 degrees shown.

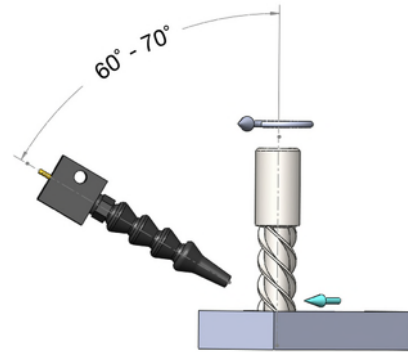

Figure 31: Vertical position of external nozzle

In peripheral milling, or when the tool is parallel to the work piece, the dead zone starts closer to 100 degrees from the nozzle. The nozzle should be placed close to horizontal spraying the tool before it enters the cut to fluid delivery. It is placed before entering the cut, not on the back side, so no chips or turbulence interrupts the aerosol flow.

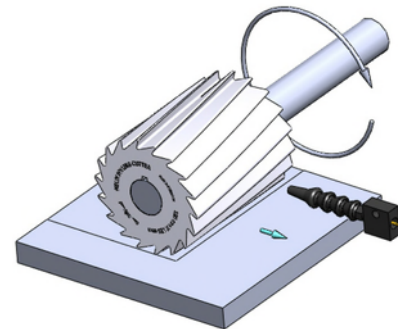

Figure 32: Optimum position of external nozzle for peripheral milling

The nozzle should be placed so that it is spraying the tool/work piece interface. In some cases this may mean the nozzle is attached to the bed or the work piece holder. In other cases it can be connected to the spindle arm. In all cases the nozzle coupler block should be level or pointed down as shown on page 22.

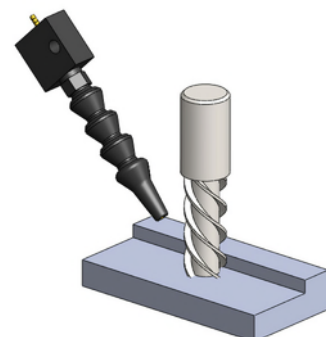

Figure 33: Nozzle positioning

System Startup

Turning The System On & Off

The Coolubricator™ is turned on or off using a manual slide valve, a solenoid valve, or an air pilot valve. If the unit is equipped with a manual slide valve, it is turned on and off by sliding the valve to the desired position. Moving the slide valve barrel toward the air filter will turn air flow to the system on. Moving the slide valve barrel away from the air filter will turn air flow to the system off.

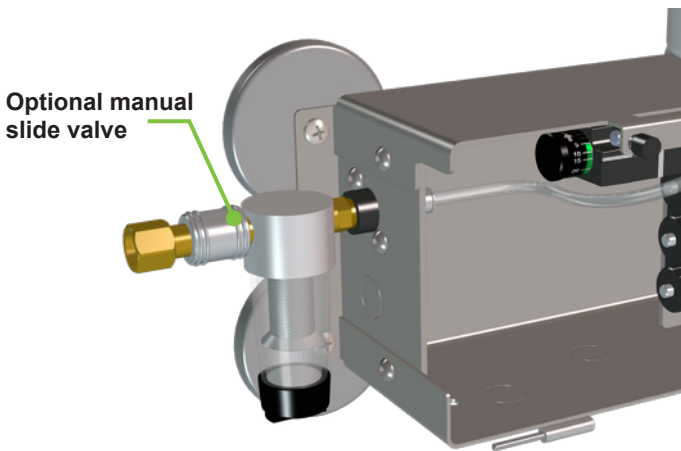

Figure 34: Manual slide valve

Solenoid control will turn on the unit when the correct electrical voltage is applied. Air pilot valve control turns on the unit when the air signal is received.

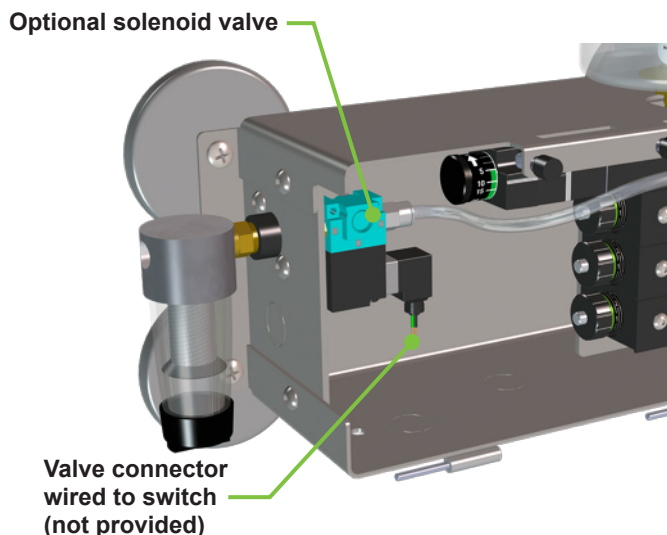

Figure 35: Remote operation

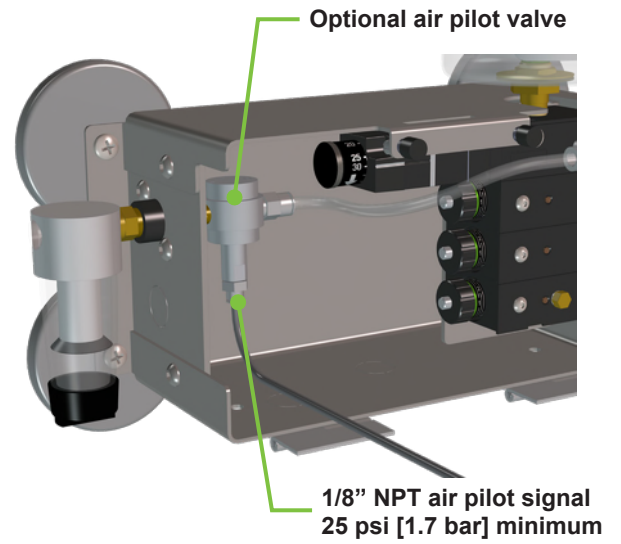

Figure 36: Pneumatic air pilot valve

Helpful hint: You can manually stroke a pump by pressing the end of the piston to move the pump's piston. This can be useful in diagnosing system problems.

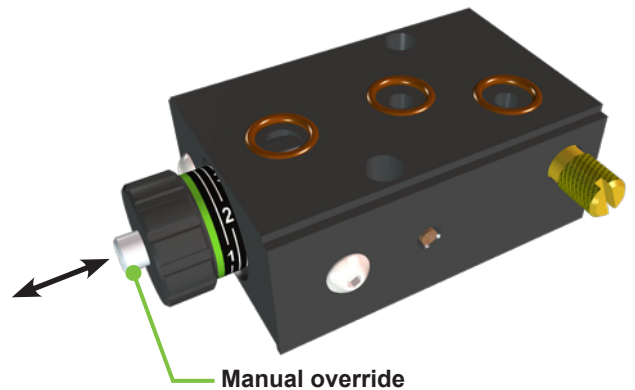

Figure 37: Manual override

System Startup

Prime The Pumps

To prime the system, use a 5/16" nut driver to turn the drain plug on the bottom pump two turns counterclockwise to bleed trapped air. Once fluid is present, close the plug; **do not overtighten or you will break the drain plug**. It is recommended a nut driver be used, and not a wrench, to reduce the chance of over tightening. The screw should be snug, tightened just enough so the fluid does not leak from the drain. A rag can be placed below the drain plug to catch the fluid.

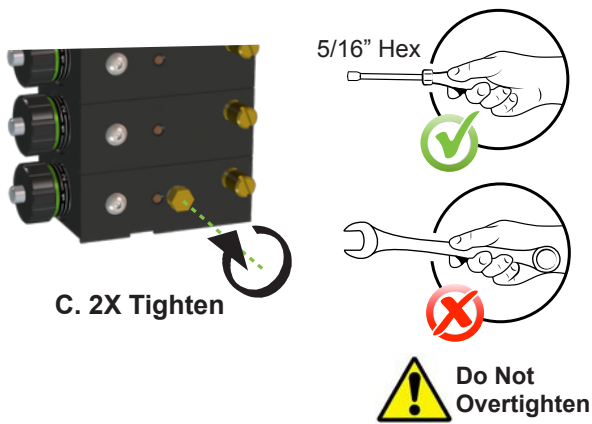
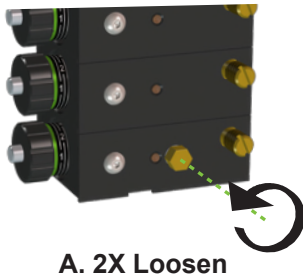

Figure 38: Priming the pumps

The priming procedure may need to be performed again if there is a lot of air trapped in the fluid path between the reservoir and the bottom pump.



Attention: Be careful to not spill any oil during the pump stack bleeding process. Clean up any spilled oil immediately as spilled oil can cause hazardous slippery conditions.

To complete pump priming, adjust the pump(s) to full stroke and then cycle repeatedly until fluid is pumping consistently. When priming is complete, adjust the pump stroke back to the previous setting.



Attention: Ensure all people are clear from the area of the system output nozzles when operating the outputs manually. Failure to do so could result in personal injury.

Setting Pump Stroke

It is suggested that the pump be left at full stroke and spray pattern adjustments are made with the pulse generator. However in cases where very low output is needed and a stable spray pattern cannot be maintained when adjusting the pulse generator alone, the pump stroke length can be decreased and the pump cycle rate increased.

NOTE: Adjustment procedure depends on the pump style

Standard pumps (pumps with a knurled brass adjustment knob):

The pump stroke is decreased by turning the knob counterclockwise. Full stroke is when the knob is turned fully clockwise.

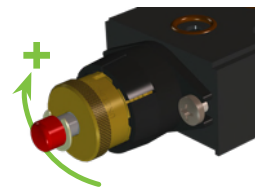

MV pumps (pumps that have a black anodized aluminum adjustment knob):

The pump stroke is decreased by turning the knob clockwise. Full stroke is when the knob is turned fully counterclockwise.

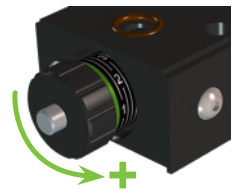

System Startup

3-Drop Standard Pump (Black Cap)



1-Drop Standard Pump (Red Cap)

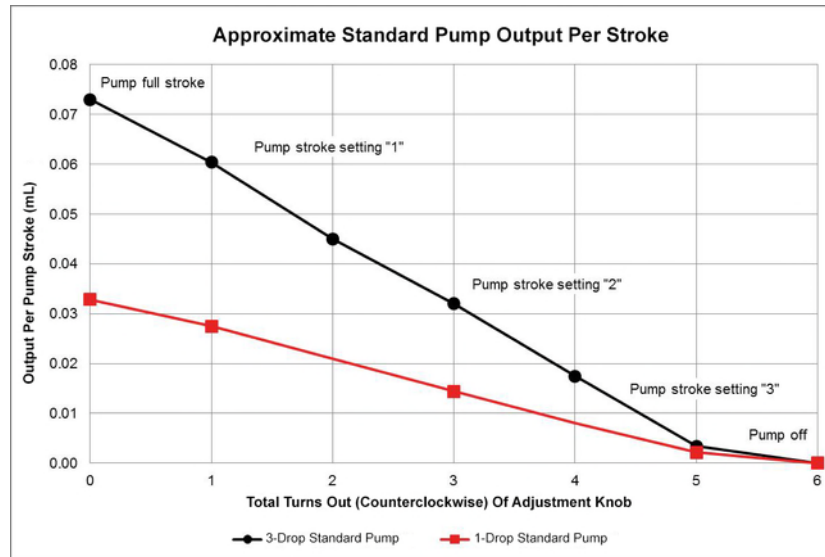

Figure 39: Approximate standard pump output per stroke

2-Drop MV Pump (Red Band)



1-Drop MV Pump (Green Band)

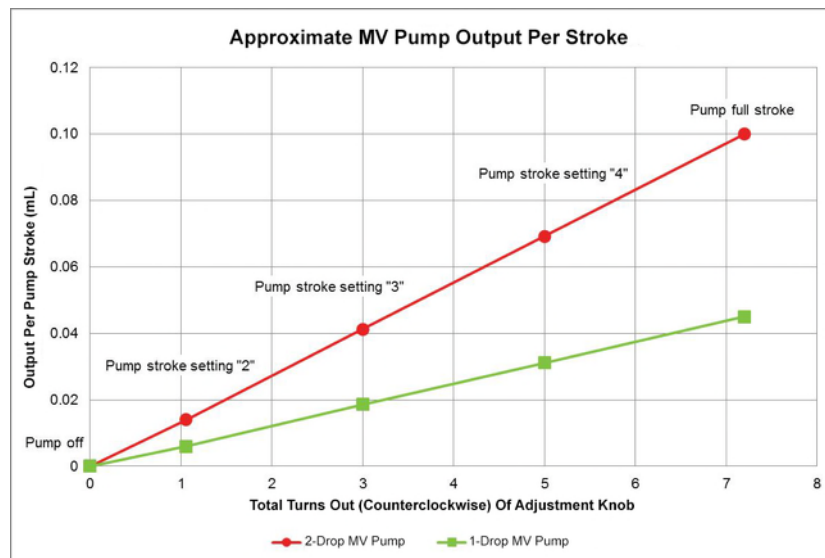

Figure 40: Approximate MV pump output per stroke

System Startup

Adjust Pulse Generator

The pulse generator is recommended as the primary fluid rate adjustment. The entire range of rates is contained in a single 360 degree rotation, so turning the knob a full turn will return the pulse generator to its initial rate.

System With Knob

Adjust the pulse generator to 10 pulses per minute by aligning the 10 on the decal with the alignment notch on the mounting block. This should result in a pulse approximately once every 6 seconds. Turning the knob clockwise decreases the frequency, counterclockwise increases it. The numbers on the dial can be used as rough approximations of the pulses per minute.

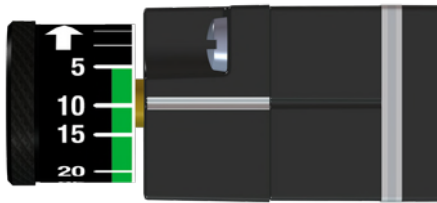

Figure 41: Pulse generator adjustment knob

System Without Knob

Adjust the pulse generator to 10 pulses per minute using a screwdriver and a stopwatch. The pump should pulse once every 6 seconds. Turning the screw clockwise decreases the frequency, counterclockwise increases it.

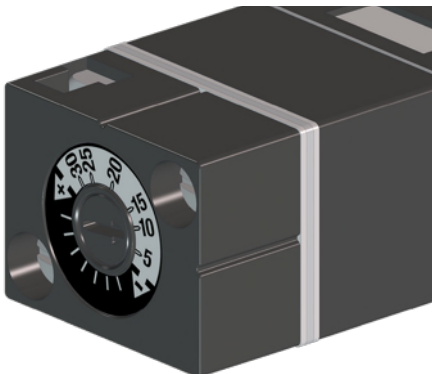

Figure 42: Pulse generator

Adjust Airflow

On atomizing pumps, the air metering screw will adjust how fine a spray is generated. Too little air will result in a pulsating and spitting spray. Too much air will create a fog of very fine mist. Adjust the air metering screw to the desired degree of atomization for the application.

The recommended initial setting for the air metering screw is found by rotating the air metering screw clockwise until it is fully seated, then backing it off 3/4 of a turn (270 degrees).

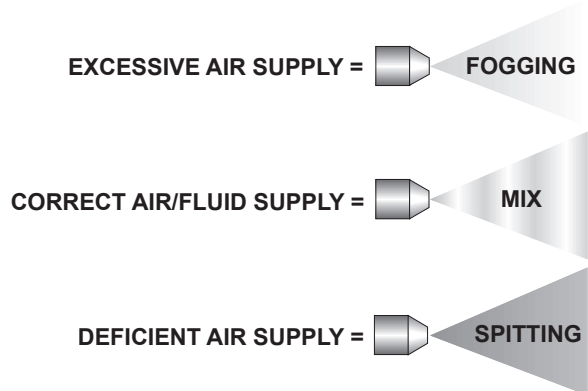
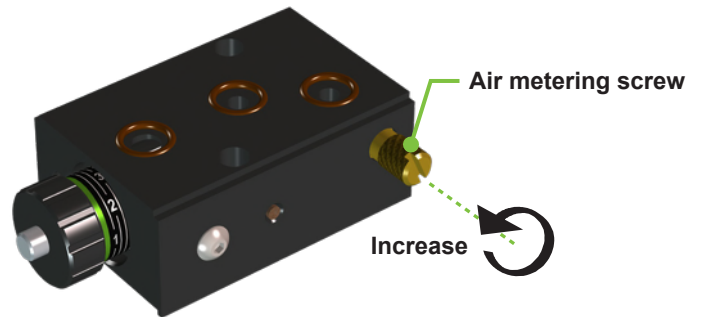

Figure 43: Adjusting airflow

NOTE: Use the minimum amount of air necessary to deliver the fluid to the point of application. Excess air flow will cause undesirable fogging!

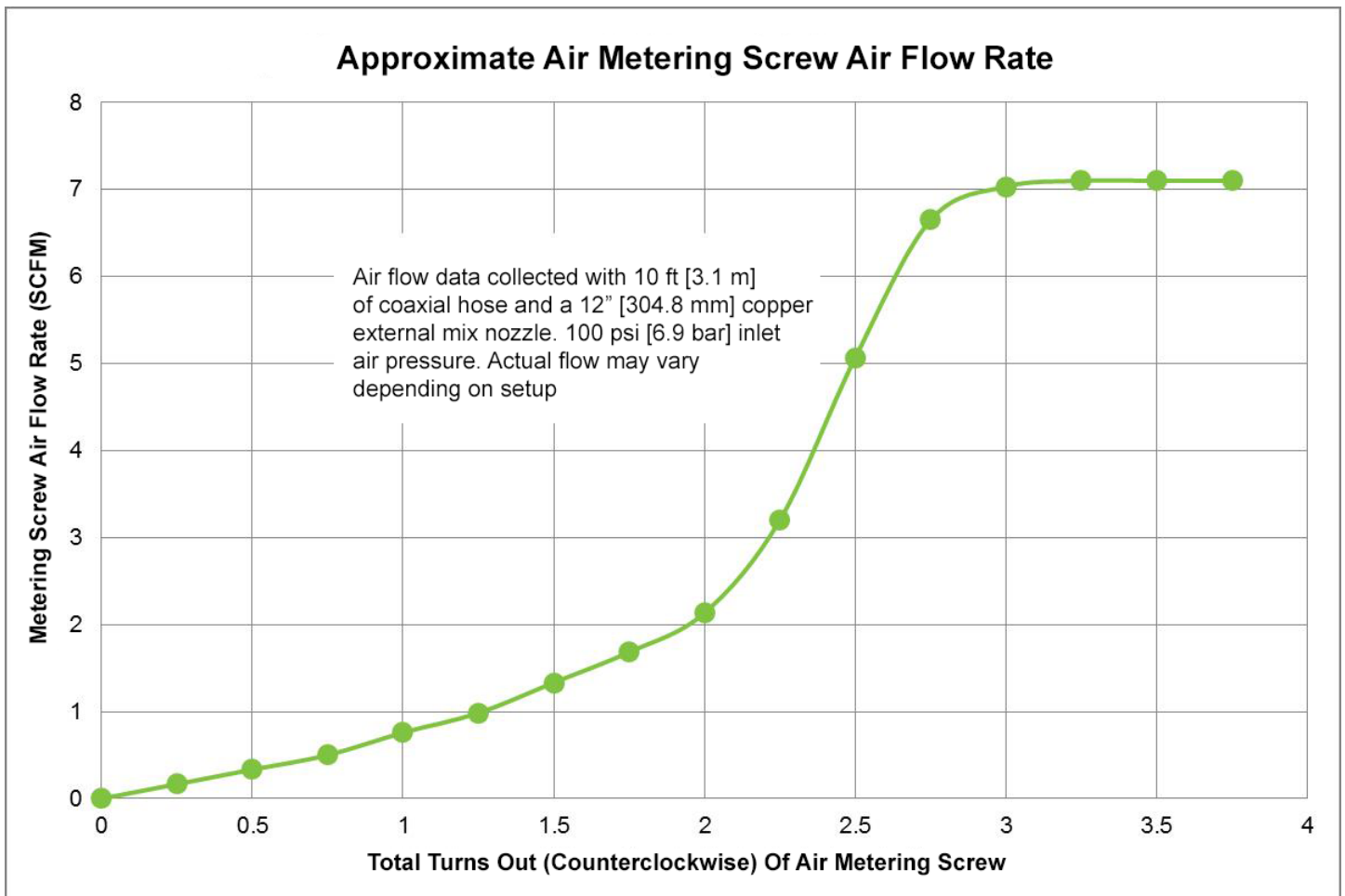

Figure 44: Approximate air metering screw air flow rate

Nozzles

Nozzle Styles

Flexible Plastic

Plastic nozzles are easy to aim to where the spray is needed, and there is no work-hardening on the nozzle if it is repeatedly bent into different shapes. The downside of this style nozzle is if there are things that can hit the nozzle, such as metal chips in cutting operations or an operator cleaning the machine, the nozzle is easily moved out of position. The spray output will have a conical shape with an included angle of approximately 15-20 degrees, depending on the amount of air introduced.

Shown with optional stainless steel tip



Figure 45: Flexible plastic nozzle

Semi-Rigid Copper

Semi-rigid copper nozzles are our most popular nozzle. They offer a nice balance of flexibility and rigidity. They are easily bent and molded to shape, and they hold that shape well when hit or impacted with moderate force. Repeated bending can cause work-hardening, and eventually the nozzle body will crack. The spray output will have a conical shape with an included angle of approximately 15-20 degrees, depending on the amount of air introduced.



Figure 46: Semi-rigid copper nozzle

Stainless Steel

Stainless steel nozzles offer very good rigidity; they are not easily bent into, or out of shape. This makes them the preferred choice when the nozzle will be put in one position, and the force expected to be exerted on the nozzle is more than a copper nozzle can withstand without deforming. The spray output will have a conical shape with an included angle of approximately 15-20 degrees, depending on the amount of air introduced.



Figure 47: Stainless steel nozzle

Fan Spray

Fan spray nozzles are useful when an elliptical spray pattern fits the application better than a conical pattern. An example of this would be coating an item coming down a conveyer line. The chart below gives approximations of the spray area coverage.

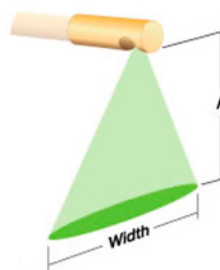

Spray Dimensions				
A	Min	Width	Max	+ / -
1.00" [25.4 mm]	1.60" [40.6 mm]	2.40" [60.9 mm]	3.20" [81.3 mm]	0.80" [20.3 mm]
2.00" [50.8 mm]	2.90" [73.7 mm]	3.80" [96.5 mm]	4.70" [119.4 mm]	0.90" [22.9 mm]
3.00" [76.2 mm]	4.10" [104.1 mm]	5.20" [132.1 mm]	6.30" [160.0 mm]	1.10" [27.9 mm]
4.00" [101.6 mm]	5.30" [134.6 mm]	6.60" [167.6 mm]	7.90" [200.7 mm]	1.30" [33.0 mm]
5.00" [127 mm]	6.50" [165.1 mm]	8.00" [203.2 mm]	9.50" [241.3 mm]	1.50" [38.1 mm]
6.00" [152.4 mm]	7.70" [195.6 mm]	9.40" [238.8 mm]	11.10" [281.9 mm]	1.70" [43.2 mm]

Figure 48: Fan spray nozzle

Nozzles

Connecting & Disconnecting Tubing & Nozzles

When ordered as a system, the nozzles, and associated tubing, will come attached to the applicator. To ease the routing of the tubing or make a cleaner installation, the tubing can be disconnected from the nozzle, trimmed to length, and reattached. Knowing the proper technique to attach the coaxial tubing to the unit or the nozzle can make this task much easier. Watching the tutorial video “**Working With The Redesigned Capillary Splicer**” found at unist.com/splice is recommended before disconnecting the tubing.

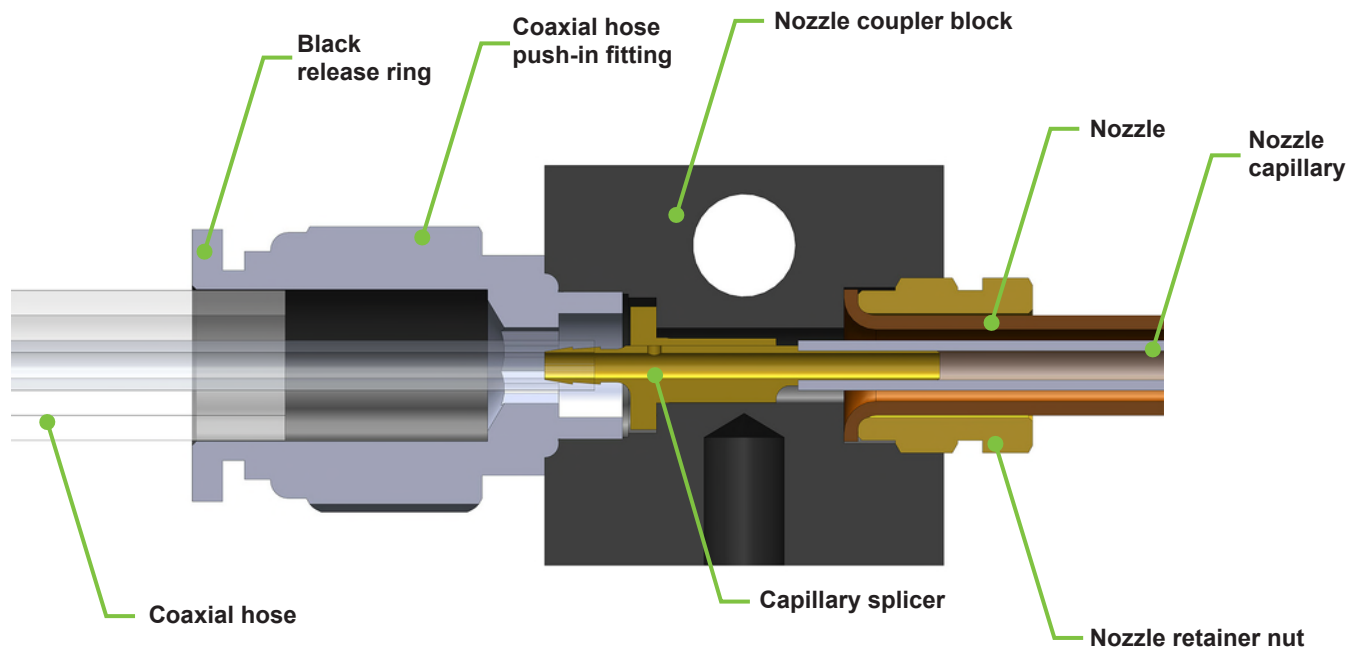

Figure 49: Capillary splicer cross section

Troubleshooting



Attention: While troubleshooting it may be necessary to access the electrical solenoid on the Coolubricator™. Only qualified individuals should perform such work and control power to the Coolubricator™. Should be turned off when accessing this enclosure.

Pump is not cycling

- Confirm pulse generator is not set to 0.
- Confirm inlet air pressure is between 60-100 psi [4-7 bar].
- Confirm that actuation of the controlling manual valve, solenoid valve, or air pilot valve allows air to flow into the system.
- Inspect the pulse generator inlet screen for debris. (See Figure 50).

No fluid output from cycling pump

- Confirm that the fluid reservoir is not empty.
- Confirm that the inlet air pressure is between 60-100 psi [4-7 bar].
- Perform the pump priming procedure, previously described in the section titled “**Prime The Pumps**” on page 15.
- Perform a pump rebuild. (Watch the video: unist.com/rebuild).

Reduced fluid output

- Confirm that the fluid reservoir is not empty.
- Confirm that the inlet air pressure is between 60-100 psi [4-7 bar].
- Confirm that the pump stroke adjustment knob is set appropriately.
- Confirm the pulse generator is set appropriately.
- Perform the pump priming procedure, previously described in the section titled “**Prime The Pumps**” on page 15.
- Perform a pump rebuild. (Watch the video: unist.com/rebuild).

Fluid flows continuously out of a nozzle without pumps cycling

- Perform a pump rebuild to replace outlet check valve seal and spring.

Air bubbling upward into fluid reservoir when system operating

- Perform a pump rebuild to replace outlet check valve seal and spring.

Fluid accumulation in outer tubing

- Increase atomizing air flow.
- Position nozzles as shown in the section titled “**Keeping fluid out of the outer tube**” on page 22.

Inspecting the pulse generator

Remove pulse generator and check air inlet screen for particulate matter. If none found, replace pulse generator. See illustration below for details on the position of the air inlet screen.

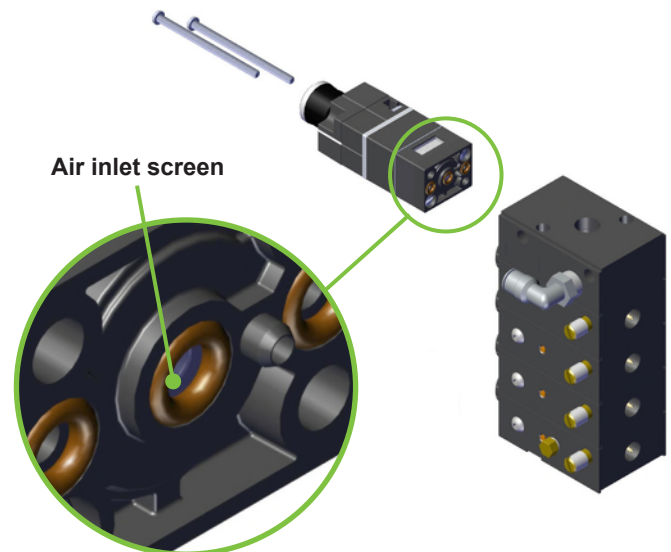

Figure 50: Air inlet screen

Troubleshooting

Keeping fluid out of the outer tube

In some instances the fluid can accumulate in the outer tubing. This is usually caused when too little atomizing air flow is used and/or the fluid line is lower than the nozzle coupler block. The problem can be alleviated by:

1. Increasing the atomizing air flow
2. Raising the fluid line so the fluid flows down into, and eventually out of, the nozzle.
3. Mounting the nozzle coupler block at an angle so fluid flows down into, and eventually out of, the nozzle. See the illustrations below for an example of how to mount the nozzle coupler block.

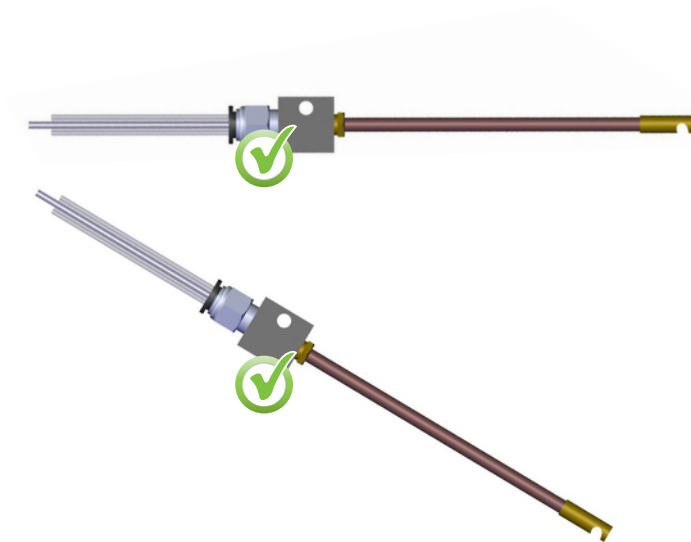

Figure 51: Correct way to mount the coupler block

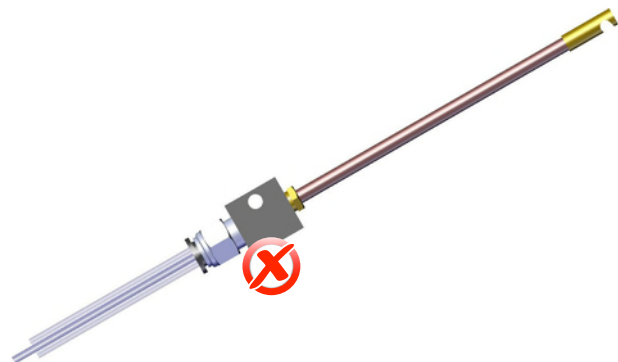
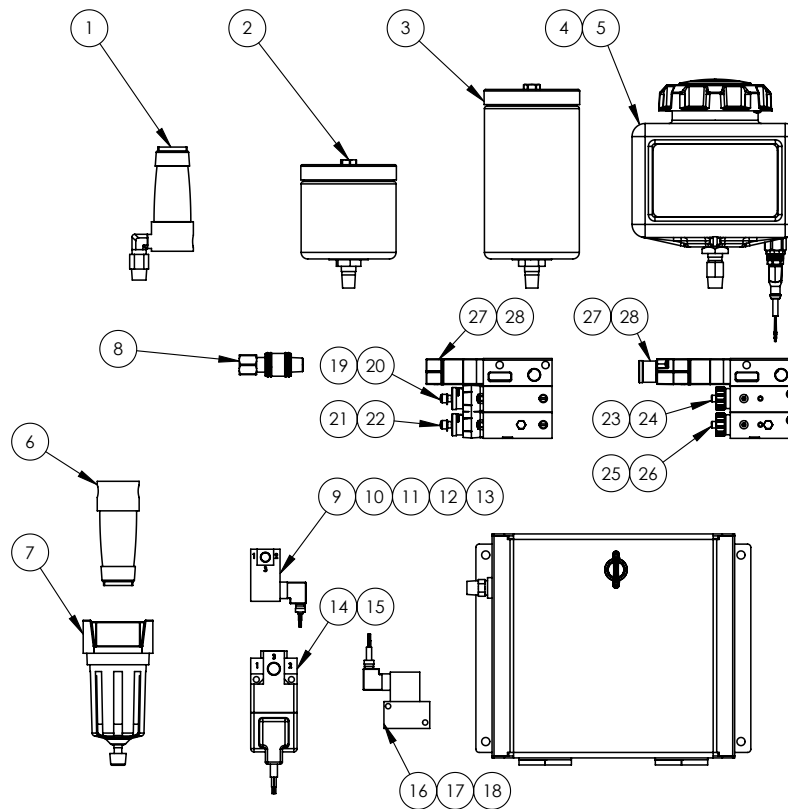

Figure 52: Incorrect way to mount the coupler block

Appendix A: System Spare Parts



28	ASSEMBLY, PULSE GENERATOR, WITH ADJUSTMENT KNOB	301930
27	ASSEMBLY, PULSE GENERATOR	60-6393
26	PUMP ASSEMBLY, BOTTOM, 1-DROP	302099
25	PUMP ASSEMBLY, BOTTOM, 2-DROP	302101
24	PUMP ASSEMBLY, INTERMEDIATE, 1-DROP	302098
23	PUMP ASSEMBLY, INTERMEDIATE, 2-DROP	302100
22	METERING PUMP, 1-DROP, BOTTOM BLOCK	94-6821
21	METERING PUMP, 3-DROP, BOTTOM BLOCK	94-6823
20	METERING PUMP, 1-DROP, INTERMEDIATE BLOCK	94-6811
19	METERING PUMP, 3-DROP, INTERMEDIATE BLOCK	94-6813
18	SOLENOID VALVE, STACKABLE, 24 VAC, W/2M DIN	68-1041-1824VAD
17	SOLENOID VALVE, STACKABLE, 110 VAC, W/2M DIN	68-1041-18-110D
16	SOLENOID VALVE, STACKABLE, 24 VDC, W/2M DIN	68-1041-1824VDD
15	Solenoid Valve, 1/4", 24 VAC, w/ 2m DIN	68-1040-24VACD
14	Solenoid Valve, 1/4", 110 VAC/24 VDC, w/ 2m DIN	68-1040-110D
13	Solenoid Valve, 1/8", 24 VAC, w/ 2m DIN	68-1040-18-24D
12	Solenoid Valve, 1/8", 12 VDC, w/ 2m DIN	68-1040-1812VDD
11	Solenoid Valve, 1/8", 220 VAC, w/ 2m DIN	68-1040-18-220D
10	Solenoid Valve, 1/8", 110 VAC, w/ 2m DIN	68-1040-18-110D
9	Solenoid Valve, 1/8", 24 VDC, w/ 2m DIN	68-1040-1824VDD
8	MANUAL SLEEVE VALVE, 1/4" NPT	69-5506
7	AIR FILTER, 1/4" NPT	F60-2
6	AIR FILTER, 1/4" NPT	69-459
5	RESERVOIR ASSEMBLY, 64 oz, W/LOW LEVEL SENSOR	301313
4	RESERVOIR ASSEMBLY, 64 oz	301311
3	RESERVOIR, 32 oz, POLYETHYLENE	69-460
2	RESERVOIR, 16 oz, POLYETHYLENE	69-459-PE
1	AIR TRAP, 1/4" NPT	6139
ITEM NO.	DESCRIPTION	PART NUMBER

Figure 53: System spare parts

Appendix B: Nozzle Spare Parts

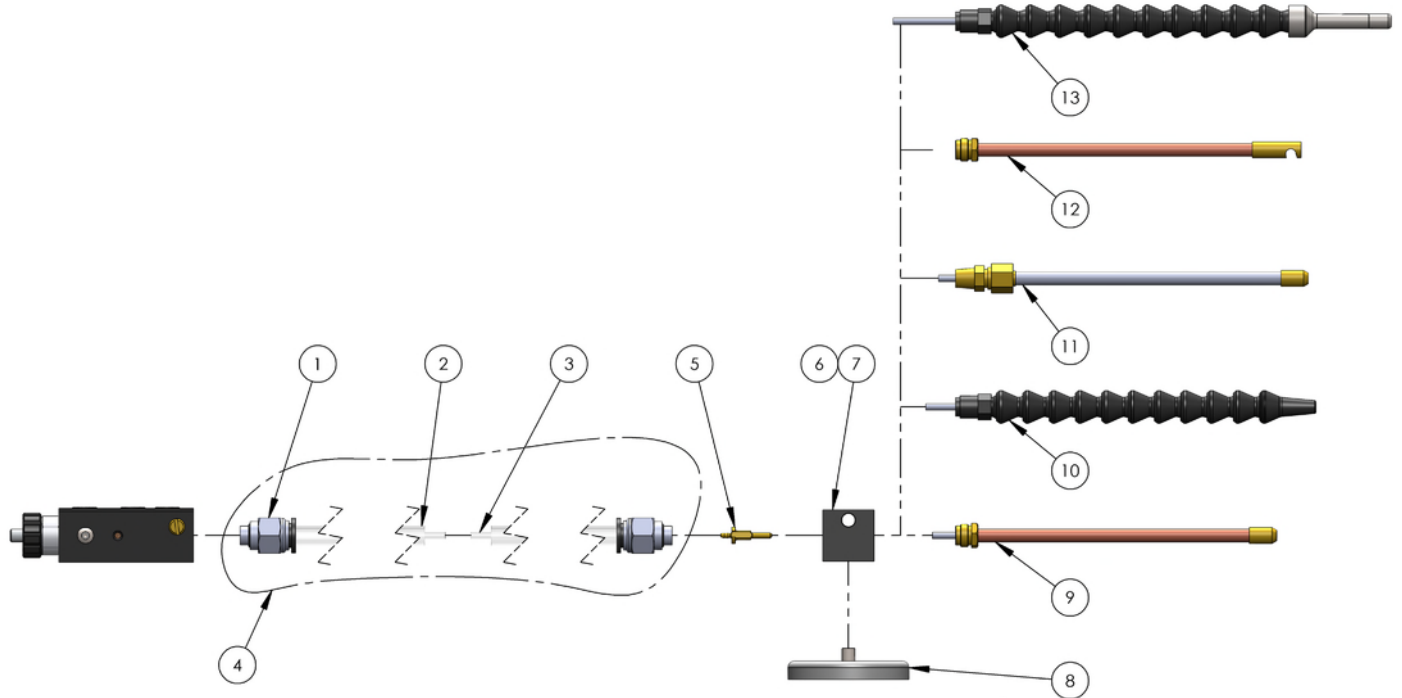

13	X" PLASTIC NOZZLE, EXTERNAL MIX, W/STAINLESS STEEL TIP	6121-P-XP-SS
12	X" COPPER NOZZLE, FAN SPRAY	60-6100-XSR-FS
11	X" STAINLESS STEEL NOZZLE, EXTERNAL MIX, 1/8 NPT	6121PT-P-XSS
10	X" PLASTIC NOZZLE, EXTERNAL MIX	6121-P-XP
9	X" COPPER NOZZLE, EXTERNAL MIX	6121-P-XSR
8	MAGNET, NOZZLE BLOCK	60-6340-22
7	NOZZLE COUPLER BLOCK, 1/8 NPT, 7/16-20	6110
6	NOZZLE COUPLER BLOCK, 1/8 NPT, 1/8 NPT	6110-3
5	SPLICER, CAPILLARY TUBING, W/O HOLE	302116
4	COAX HOSE, W/ FITTINGS, TBD' LG.	6123PT-TBD
3	TUBING, 1/8 OD NYLON CAPILLARY, TBD' LG.	71-2050
2	3/8" OD TUBING, POLYURETHANE, TBD' LG.	6100-TBD
1	PUSH IN FITTING, 3/8" X 1/8" UNIVERSAL PIPE THREAD	301875
ITEM NO.	DESCRIPTION	PART NUMBER

Figure 54: Nozzle spare parts

Appendix C: Standard Pump Components

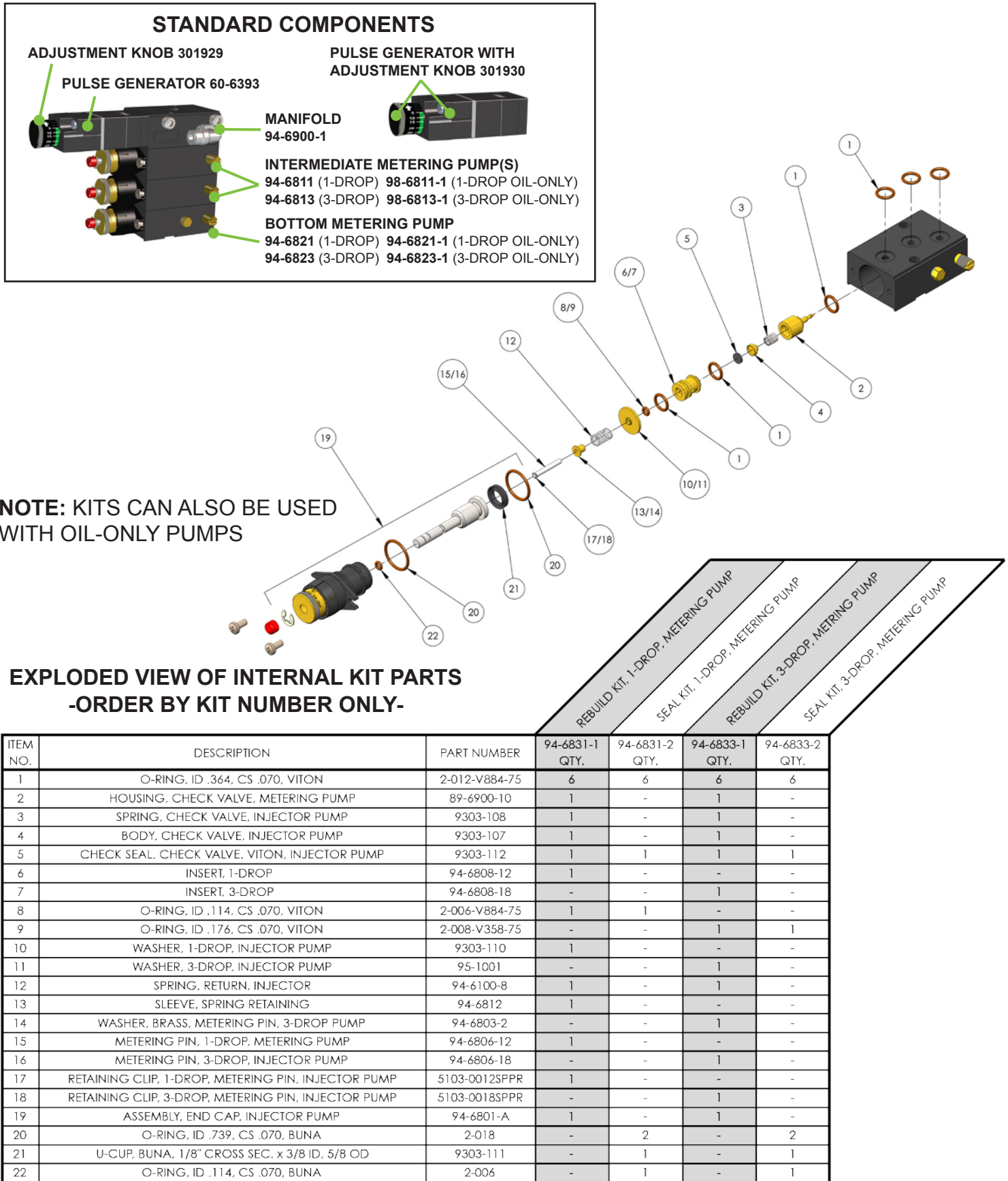
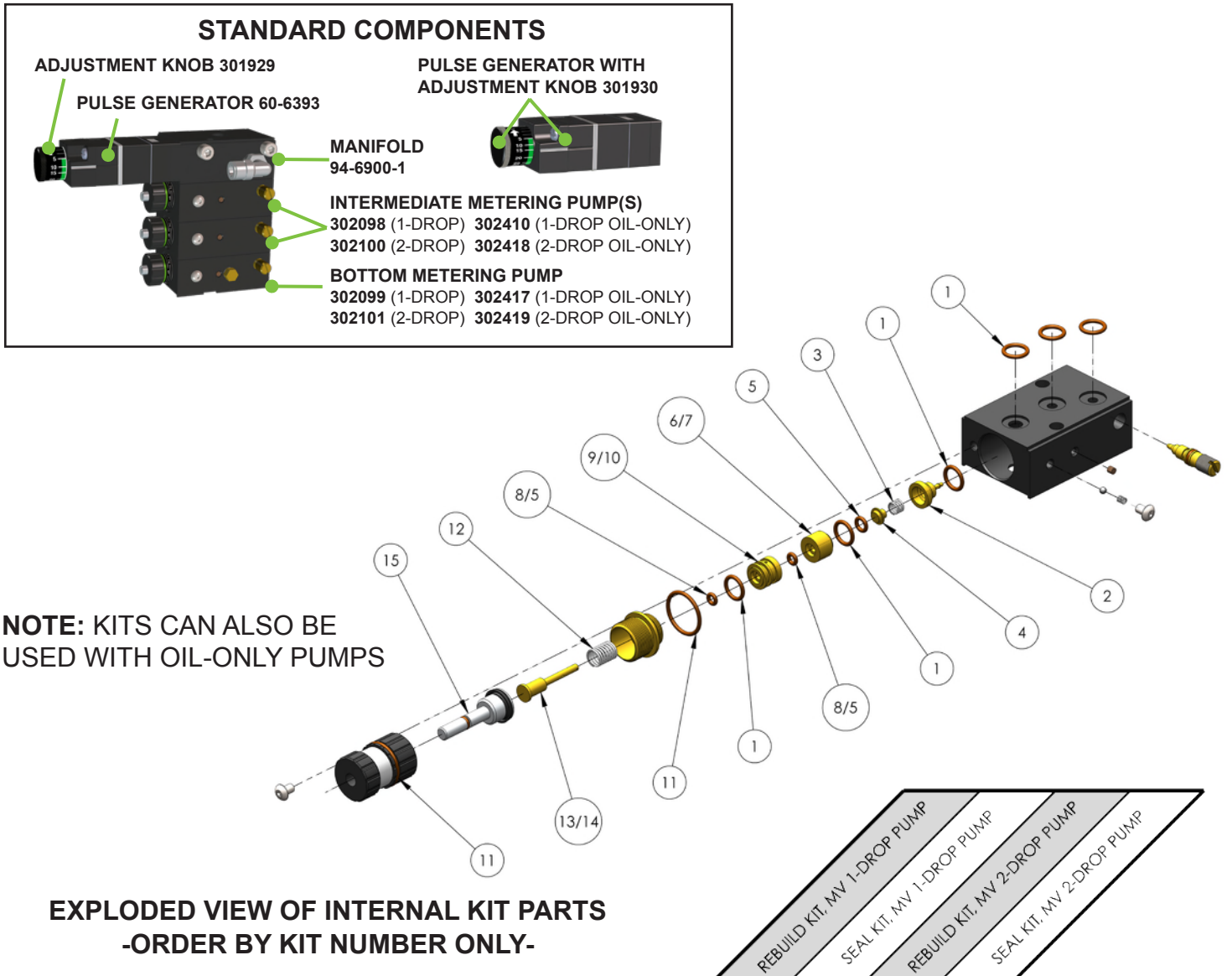

Figure 55: Standard pump components

Appendix D: MV Pump Components



EXPLODED VIEW OF INTERNAL KIT PARTS -ORDER BY KIT NUMBER ONLY-

ITEM NO.	DESCRIPTION	PART NUMBER	301877 QTY.	302291 QTY.	301878 QTY.	302292 QTY.
1	O-RING, ID .364, CS .070, VITON	2-012-V884-75	6	6	6	6
2	HOUSING, CHECK VALVE, OUTLET	301848	1	-	1	-
3	SPRING, OUTLET CHECK VALVE	301850	1	-	1	-
4	BODY, OUTLET CHECK SEAL	301849	1	-	1	-
5	O-RING, ID .176, CS .070, VITON	2-008-V358-75	1	1	3	3
6	INSERT, METERING PIN, LOWER, 1-DROP	301851	1	-	-	-
7	INSERT, METERING PIN, LOWER, 2-DROP	301852	-	-	1	-
8	O-RING, ID .114, CS .070, VITON	2-006-V884-75	2	2	-	-
9	INSERT, METERING PIN, UPPER, 1-DROP	301853	1	-	-	-
10	INSERT, METERING PIN, UPPER, 2-DROP	301854	-	-	1	-
11	O-RING, ID .739, CS .070, BUNA	2-018	2	2	2	2
12	SPRING, PISTON RETURN	301859	1	-	1	-
13	METERING PIN, BALL CHECK VALVE, 1-DROP ASSEMBLY	301870	1	-	-	-
14	METERING PIN, BALL CHECK VALVE, 2-DROP ASSEMBLY	301871	-	-	1	-
15	PISTON ASSEMBLY, INJECTOR PUMP	301872	1	1	1	1

Figure 56: MV pump components

Appendix E: System Part Numbering Scheme

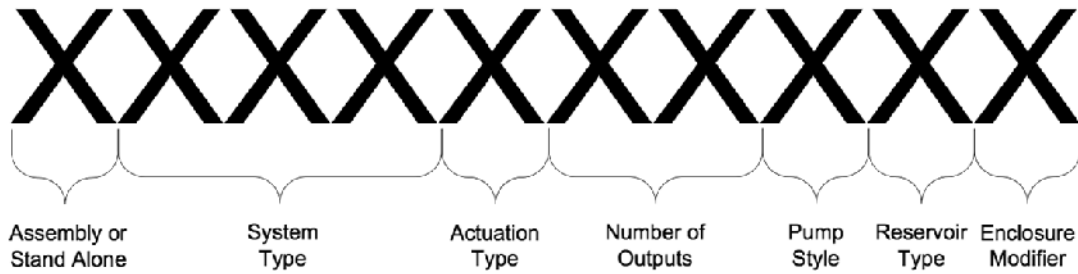

1st Character: Assembly or Stand Alone

Designator	Description
A	Assembly-Mated w/ outputs
S	Stand Alone-No output/System only

2nd, 3rd & 4th Character: System Type

Designator	Description
100	Coolubricator

5th Character: Actuation Type

Designator	Description
A	110VAC Solenoid-Common Actuation
B	24VAC Solenoid-Common Actuation
C	220VAC Solenoid-Common Actuation
M	440VAC Solenoid-Common Actuation
D	24VDC Solenoid-Common Actuation
N	12VDC Solenoid-Common Actuation
Q	24VDC/110VAC Solenoid-Common
F	24VAC Solenoid-Independent Actuation
G	24VDC Solenoid-Independent Actuation
E	110VAC Solenoid-Independent Actuation
P	220VAC Solenoid-Independent Actuation
H	Air Pilot Valve
J	Air Pilot Valve with Foot Pedal
K	Manual Valve
X	No Valve

6th & 7th Character: Number of Outputs

Designator	Description
01-16	1-16 outputs

8th Character: Pump Style

Designator	Description
A	Standard 1-drop
B	Standard 3-drop
C	MV 1-drop
D	MV 2-drop

9th Character: Reservoir Type

Designator	Description
B	16 oz
C	32 oz
D	64 oz
E	64 oz w/ Low Level Option
F	Air Trap Kit
X	No Reservoir

10th Character: Enclosure Modifier

Designator	Description
A	Standard Enclosure
B	Standard Enclosure w/ Magnet Mount
C	Standard Enclosure w/ Key Lock
D	Standard Enclosure w/ Magnet Mount & Key Lock
E	No Enclosure & Bottom Magnet Mount
X	No Enclosure

Figure 57: System part numbering scheme

Appendix F: Nozzle Part Numbering Scheme

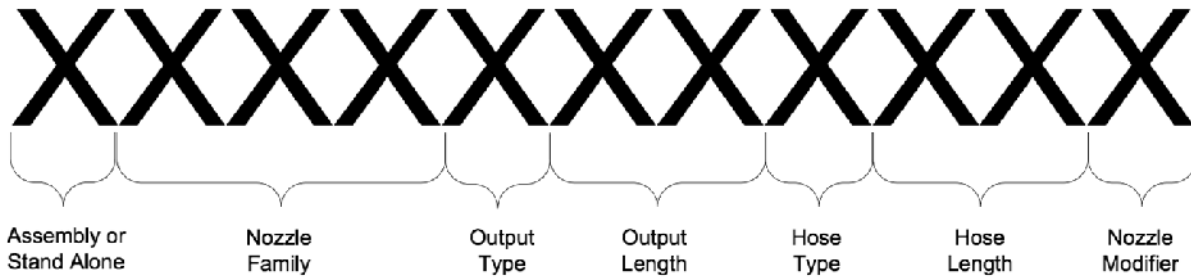

1st Character: Assembly or Stand Alone

Designator	Description
A	Assembly-Mated w/ system
S	Stand Alone-No system. Outputs only.

2nd, 3rd & 4th Character: Nozzle Family

Designator	Description
101	Coolubricator Nozzle

5th Character: Output Type

Designator	Description	Use with system type
A	1/4"-Flexible Plastic	100, 200
B	1/4"-Semi-Rigid Copper	100, 200
C	1/4"-Stainless Steel	100, 200
D	1/4"-Flexible Steel	100, 200
E	3-outlet BAT ¹	100
K	Guide Lube Point 1/8" NPT - Ftg ¹	100
L	Guide Lube Point 1/4" NPT - Ftg ¹	100
M	1/8" OD Copper Nozzle	100
N	Splitter ²	100
P	1/4"-Copper Fan Spray	100, 200
R	Band Saw Blade Nozzle ¹	100
S	Band Saw Guide Nozzle ¹	100
T	1/4"-Plastic w/ Stainless Tip	100, 200

¹Nozzle Modifier does not apply

²Articulated Arm does not apply

6th & 7th Character: Output Length (6" increments standard. Special lengths additional cost)

Designator	Description
06-36	Length (in inches) ¹
XX	Predefined Length Nozzle

¹on 1.63" BAT use 01. BAT limited to 01, 03 & 07

Splitters limited to 06,12,18

Use 00 for guide lube

Band Saw Blade use 01, 02 or 03

8th Character: Hose Type

Designator	Description	Use with system type
A	Polyurethane Coaxial Hose	100, 200
B	Braided Stainless Steel Coaxial Hose	100, 200
C	1/8" Coiled Tubing (10' long minimum)	100
D	1/8" Straight Tubing	100

9th & 10th Characters: Hose Length (5ft increments standard. Special lengths additional cost)

Designator	Description
05-50	Length (in feet)

11th Character: Nozzle Modifier

Designator	Description
A	Standard (Magnet Only)
B	Articulated Arm Only
C	Magnet & Articulated Arm
X	No Magnet, No Articulated Arm

Figure 58: Nozzle part numbering scheme



Unist, Inc.
4134 36th Street SE
Grand Rapids, MI 49512 USA
U.S. & Canada: 800.253.5462
International: 616.949.0853
Email: salesupport@unist.com